



得豐實業有限公司

Dfwisdom Industrial CO., LTD

HPS-S-D 線形電位器 (Linear Wire Potentiometer)

量測行程 500 / 100 mm
 界面: RS 485 MODBUS RTU Output

DIMENSION

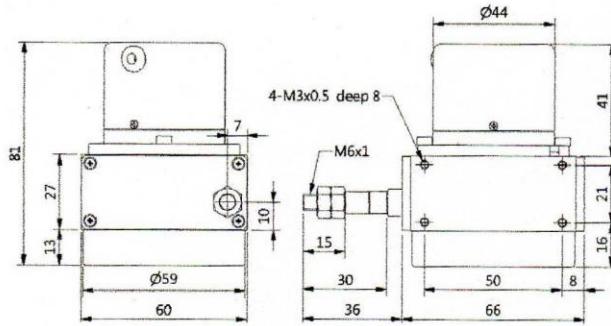

ELECTRICAL SPEC 電器規格

Full Stroke (mm) 量測行程	500,1000
Sensor	Wire-wound and hybrid potentiometer
Output Signal Mode 輸出信號模式	RL VH VL 50Ω > 2V < 0.2V 27Ω > 1.5V < 0.2V
Resolution 解析	< 0.025 % (mcu AD 解析) / 12 bit (4096)
Linearity 線性度	[standard class] ±0.15 % FS (±1 count); [precision class] ±0.1 % FS (±1 count)
Repeatability 重覆性	±0.08 % FS
Input Power 供應電壓	DC 12 - 24Vdc ±20%
Input Current 供應電流	20 mA max.
Output Short Protection 輸出短路保護	< 50 mA
Polarity Reverse Protection 極性保護	Input voltage polarity reverse protection 8 - 26 Vdc

MECHANICAL SPEC 機械規格

Wire Specification 線徑規格	Material : SUS304 with nylon coating ; Diameter : 0.7 mm ; Breaking load : 23 Kg
Starting Torque on Spring 拉力	< 600g
Max.Travel Speed 最大往復速度	500 mm/sec.
Vibration 震動	10 - 55 Hz / 1.5mm Vpp / 10 G (Max.)
Cable 電線	ø 4.5 , 100 cm long
Weight 重量	< 450 g

ENVIRONMENTAL SPEC 環境規格

Operating Temp./ Humidity	0°C ~ 70°C , RH 35 % ~ 90 % (No Condensation)
操作溫度/濕度	
Storage Temp. 儲存溫度	-20°C ~ 80°C
Protection 保護等級	IP 50:Dust Proof (only for potentiometer housing)

R-S485 MODBUS RTU Communication 通訊協議

Baud Rate 傳輸速度	19200 (Programming 可修改)
Data Bit 資料位元	8 (Fix 固定)
Parity Check 極性檢查	N (Fix 固定)
Stop Bit 停止位元	2 (Fix 固定)
Device Address 產品位址	00 (Programming 可修改)

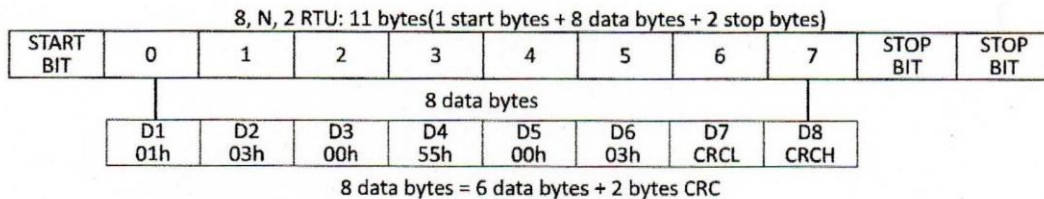



得豐實業有限公司

Dfwisdom Industrial CO., LTD

HPS-S-D 線形電位器 (Linear Wire Potentiometer)

6 data bits (Readout Data) 6位數讀出數據

01	03	0000	0000	D1	D2	D3 / D4	D5 / D6
01	03	0003		0003		0001	
Device Readout Address		Readout Data		Readout Data		Readout Data Value (16h)	
Code		Address		Address		Value	
		0003		0-10000			

6 data bits (Write Data) 6位數寫入數據

01	06	0000	0000	D1	D2	D3 / D4	D5 / D6
01	06	0000		0000		0000	
Device Write Address		Write Data Address		Set Data Address		Data Value	
Code		Address		Address		Value (16h)	
		0000		Write Address		0000~00FF(256)	
		0001		Write Baud Rate		0001~0005(5) 0001: 9600 0002: 19200 0003: 38400 0004: 57600	

Factory Fault 出廠設定

original parameters 原始參數

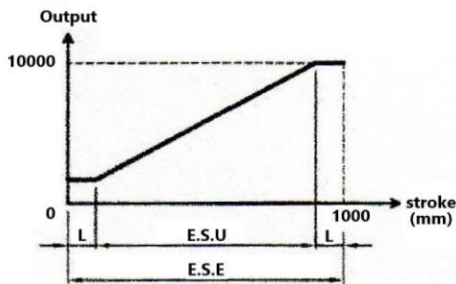

E.S.E 有效電子行程(mm)	500	1000
E.S.U 使用電子行程(mm)	5 ~ 495	5 ~ 995
Accuracy 精度	± 0.15%FS	
Repeatability Error 重覆性誤差	± 0.08%FS	

Electrical Connection 電氣連接



Programming of the start and end 開始和結束的編程

Pulling stainless wire according to the demand at the start position, connect signal ZERO (Green Wire) to GND (Black Wire) for a short circuit.

Pulling stainless wire according to demand at the end position, connect signal SPAN (Yellow Wire) to GND (Black Wire) for a short circuit.

將鋼索拉至預計開始的行程，連接 ZERO (綠線) 和 GND (黑線) 短路至少1秒。

將鋼索拉至預計結束的行程，連接 SPAN (黃線) 和 GND (黑線) 短路至少1秒。

Specifications Model 規格 型號

HPS - S -	[]	-	[]	-	[]	-	[]
	Measuring Range 量測行程		Signal Mode 信號模式		Pot Life & Linearity 壽命		Signal Sequence 信號輸出序列
	05 : 500 mm 10 : 1000 mm		D : RS-485		* F : 5 x 10 ⁶ cycles, linearity 0.1 % FS		* W : Reversed