

PVA 壓力感測器(流體) Pressure Sensor(Fluid)

本壓力感測器係PVA型壓力感測器將放大線路埋於感測器內，可避免因導線所造成之誤差和干擾，有±5V，±10V或4-20 mA三種輸出可供選擇，本感測器經精確之溫度補償，感測結構並以密封方式保護，以達到最高之量測準確度，其量測準確度優於一般以矽晶做成之感測器具以下之特點：

This pressure sensor is a upgraded version of PAV sensor and it is also a precision strain gage transducer. It uses the PV pressure sensor and hide the amplifier. It has ±5V，±10V 4-20 mA output to meet different applications.

● 特點 Features

密封保護 Hermetically Sealed

高精度 High Accuracy

PVA - 10, 20, 35, 50, 100, 200, 350, 500, 750, 1000 kg / cm²

溫度變化補償 Thermally Compensated

不銹鋼感應元件 Stainless Diaphragm

● 安裝尺寸 Installation Dimensions

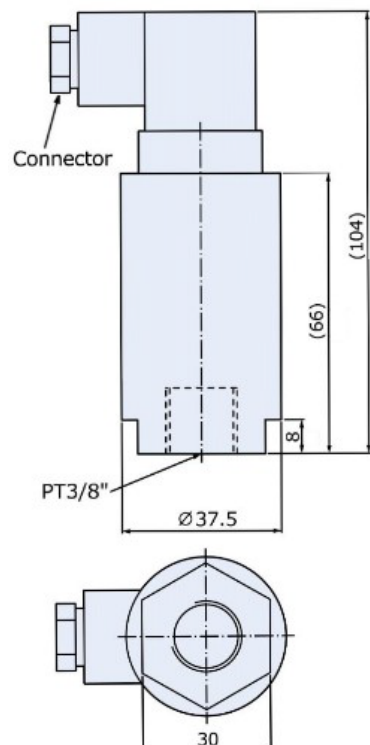

● 規格 Specification

額定輸出 Rated Output	4 ~ 20 mA or ±5V or ±10V ±0.2%	
總和誤差 Total Error	±0.1%R.O.(PV 5 ~ 50 : ±0.2%R.O.)	
重現性 Repeatability	±0.05%R.O.(PV 5 ~ 50 : ±0.1%R.O.)	
潛變 Creep	0.05% / 20min	
最大輸入電源 Max. Excitation Voltage	24VDC	
最小輸入電源 Recommended Excitation Voltage	12VDC(5V, 4 - 20 mA), 15VDC(10V)	
使用範圍 Safe Temp. Range	-20°C ~80°C	
溫度對零點之影響 Temp. Effect on Zero Balance	0.05%R.O. / 10°C	
溫度對額定輸出之影響 Temp. Effect on Rated Output	0.03% Load / 10°C	
零點誤差 Zero Balance	0.5V	
容許負荷 Safe Over Load Rating	150%	
接線方式 Cable Connection	Power : 1(+VDC) 2(GND) Output : 3(Signa) 4(GND)	
訂購編號 Ordering Information	PVA ----- 10 ----- 10 -----	
型式 Type	額定壓力 Rated pressure (in kg / cm ²)	額定輸出 Rated output 5 for 5V 10 for 10V 20 for 20mA