



得豐實業有限公司

Df Wisdom Industrial CO., LTD

TWL 無線扭力感測器 sensor

本TWL感測器結合本公司扭力感測器、微型信號處理技術及無線信號傳輸技術而成之高精度一體式荷重元，係專為扭力量測所設計，中心具對心凸圓。使對心精確，感測結構並以密封方式保護，以達到最高之量測準確度，具藍芽傳輸。具有以下特點：

This is a shear - beam type load cell. Its hermetically sealed and high sensitivity make the load cell be ideal for using in high structure , it is very accuracy truck scales. weight and automatic weighing machines.



● 特點 Features

高精度 High accuracy

溫度補償 Thermally compensated

密封保護 Moisture proof

藍芽傳輸 Bluetooth transmission

雙向 Bi - Directional

TWL - 2 , 5 , 10 , 20 , 50 , 100 , 200 , 350 , 500

1K, 2K, 3K, 5K, 10K, 15K, 20K Nm

● 安裝尺寸 Installation Dimensions

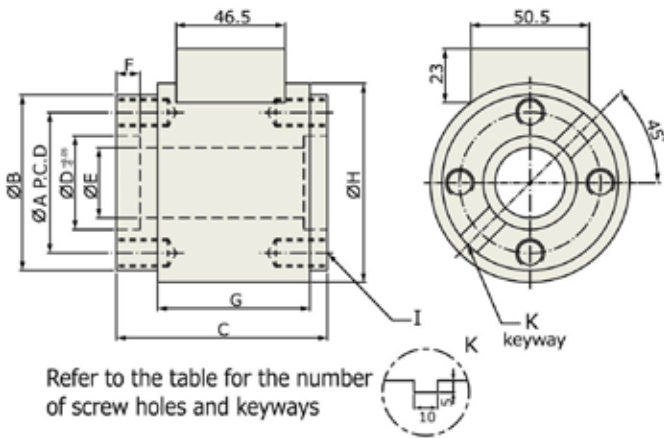

● 規格 Specification

解析度 Resolutions	20000 (TO : 1 - 1 : 5000)
總和誤差 Total Error	±0.3%R.O.
重現性 Repeatability	±0.2%R.O.
潛變 Creep	0.1% / 20min
輸入阻抗 Input Resistance	430 or 405 ± 25 Ω
輸出阻抗 Output Resistance	350 ± 5 Ω
最大輸入電源 Max. Excitation Voltage	20V
建議輸入電源 Recommended Excitation Voltage	10V
溫度補償範圍 Compensated Temp. Range	-10°C ~ 50°C
使用範圍 Safe Temp. Range	-20°C ~ 70°C
溫度對零點之影響 Temp. Effect on Zero Balance	0.05%R.O. / 10°C
溫度對額定輸出之影響 Temp. Effect on Rated Output	0.03% Load / 10°C
零點誤差 Zero Balance	±3%R.O.
容許負荷 Safe Over Load Rating	150%
電池續航 Battery life	4 hour
藍芽傳輸距離(無障礙) Bluetooth transmission distance	10 m
配合手機系統 With mobile phone system	安卓 Android

TYPE	A	B	C	D	E	F	G	H	I	K
TWL - 2 Nm					X	4				
TWL - 5 Nm				20	10					
TWL - 10 Nm	35	50	60		14	9	55	57	(4)M8x1.25 x14 deep	X
TWL - 20 Nm										
TWL - 50 Nm				20	X					
TWL - 100 Nm										
TWL - 200 Nm	60	75	90	40	32	6	65	85	(8)M12x1.75 x20 deep	(4)10x5
TWL - 500 Nm										
TWL - 1 k Nm										
TWL - 2 k Nm	90	112	110	X	74	X	77	124	(16)M12x1.75 x25 deep	(8)10x5
TWL - 3 k Nm										
TWL - 5 k Nm										
TWL - 10 k Nm	90	118	110	X	74	X	77	130	(16)M12x1.75 x25 deep	(8)10x5
TWL - 15 k Nm										
TWL - 20 k Nm										